

Compact, Safe Heating for Gases, Solvents, Volatiles & Viscous Fluids



The **DFX 750** is a compact, electric in-line circulation heater designed to quickly and safely heat liquids and gases. This cast-in-aluminum heat exchanger heats fluids indirectly providing a clean heating environment. This design also protects oils and other viscous fluids from thermal breakdown often found in direct immersion applications. The heater elements are protected from corrosive attack and yet provide rapid heat up of process fluids. The excellent thermal conductivity of aluminum provides fast

thermal response and excellent controllability. Optional dual fluid path designs provide heat/cool capabilities for precise solvent, volatiles and viscous liquid temperature control. Or the dual tubing can be used to double the flow rate, halve the pressure drop or be used in a heat/heat configuration.

DESIGN FEATURES

- **Low Mass Design**
 - enables quick thermal response
 - ensures excellent controllability
- **Seamless 316 SS Flow Tubing**
 - provides clean, contamination-free application
 - prevents internal leaks
 - allows up to 3,000 psi rating
- **Cast Aluminum Heat Exchanger Body**
 - enables indirect fluid heating
 - ensures robust, ruggedized performance
 - promotes long heater life
- **Dual Fluid Path Capability**
 - permits precision heat/cool temperature control
 - provides higher flow rate capability
- **UL® Recognition & Certified Ex-Enclosures**
 - safe laboratory and industrial use
 - North American and European HazLoc ratings

APPLICATIONS

- Liquids:**
 - De-ionized water
 - Water, glycol & CIP solutions
 - Lube and heat transfer oils
 - Adhesives, resins & other viscous fluids
 - Temp sensitive inks, coatings & paints
- Solvents:** ACT, EKC, MEK, NMP, Others
- Gases:**
 - Nitrogen & similar gases
 - Supercritical cleaning
 - Steam generation & superheating
 - Sterilization gases
 - Other non-flammable gases

SPECIFICATIONS

Series 750 Construction: 0.75" (19mm) x 0.065" (1.65mm) wall x 227" (575 cm) long, 316 stainless steel fluid tubing embedded in cast, grounded, aluminum heating body

Fluid Connections: Tube ends

Temperature Range: To 200°C (392°F)

Pressure Rating: To 3000 psi (205Bar)

Voltage: To 480V~ (ac), single or three phase

Wattage: To 40,000 Watts

Mounting: Two brackets, with mounting holes

Electrical Enclosure: NEMA 1 standard

OPTIONS

- Heat/Cool configuration
- Process and high limit temperature sensors
- Thermostats for direct or pilot duty control
- Replaceable high limit thermal cutoff device
- NEMA 4, 7, NEC Class 1, Division 2, or ATEX rated electrical enclosure
- Passivated and electropolished wetted surface
- Insulated body up to 200°C (392°F) operation
- Stand-off electrical enclosure

Use the graphs below as a general guide to assess pressure drop across the heater in various flow situations. Values are approximate and will vary with changes in pressure and flow conditions.

Pressure Drop Data for Water-Based Solutions

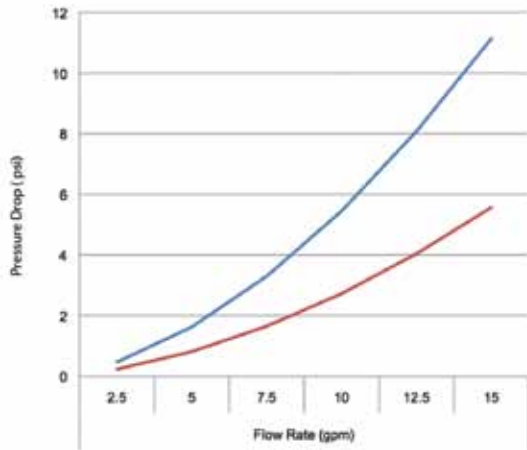

— Single Tube
— Dual Tube Water at 60°C and 100 psig

Pressure Drop Data for Air & Similar Gases

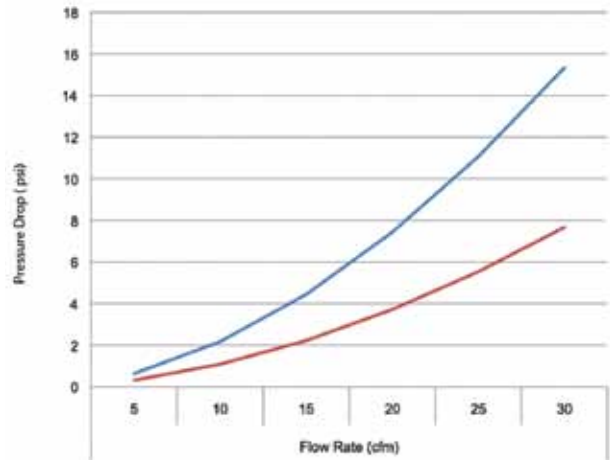

— Single Tube
— Dual Tube Dry Air at 50°C and 100 psig

DIMENSIONAL DATA

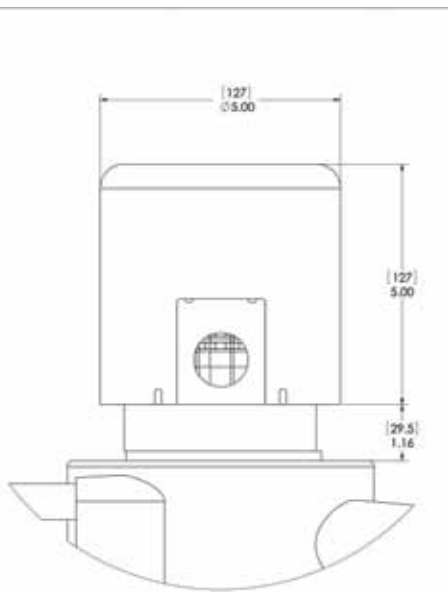

NEMA 1 Enclosure

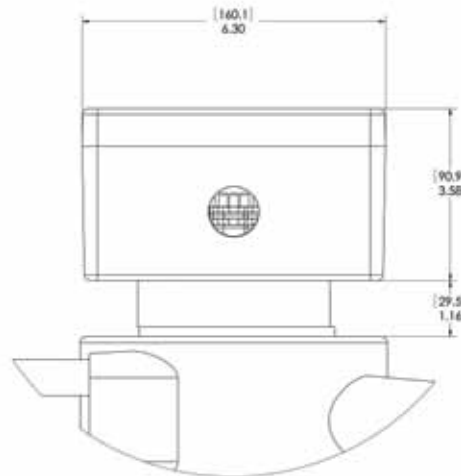

NEMA 4 Enclosure

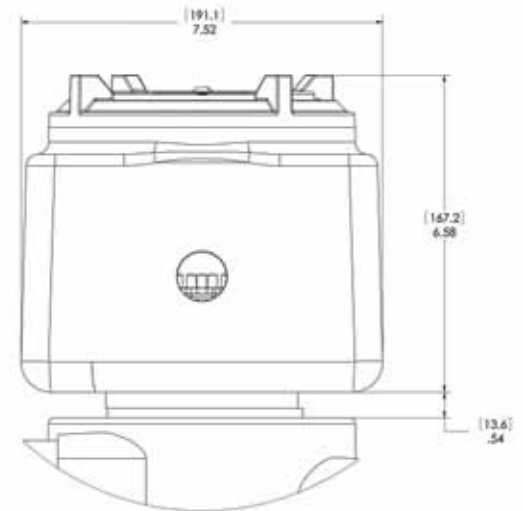

NEMA 7 Enclosure

Use the graphs below as a general guide to assess pressure drop across the heater in various flow situations. Values are approximate and will vary with changes in pressure and flow conditions.

Pressure Drop Data for Water-Based Solutions

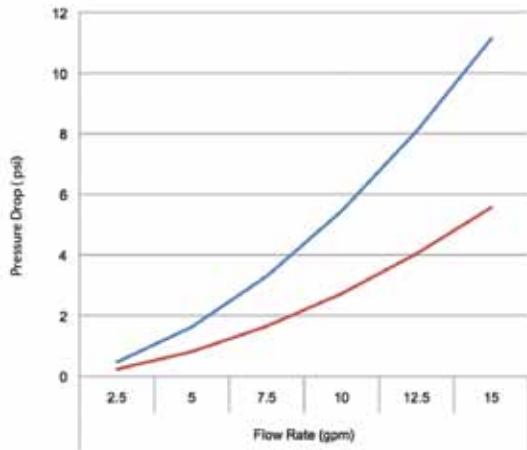

— Single Tube
 — Dual Tube Water at 60°C and 100 psig

Pressure Drop Data for Air & Similar Gases

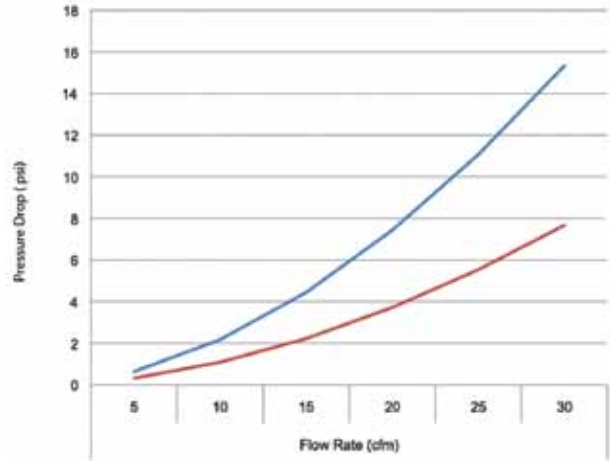

— Single Tube
 — Dual Tube Dry Air at 50°C and 100 psig

DIMENSIONAL DATA

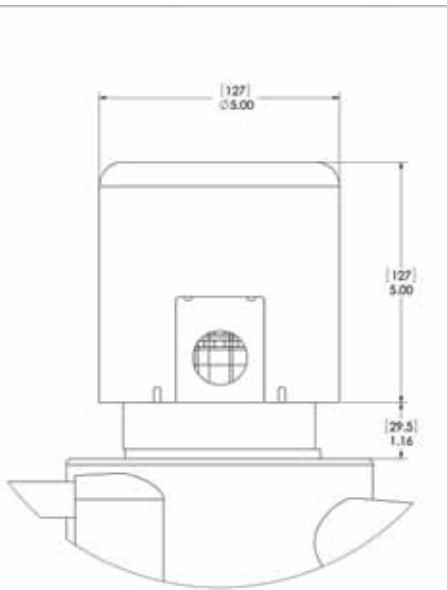

NEMA 1 Enclosure

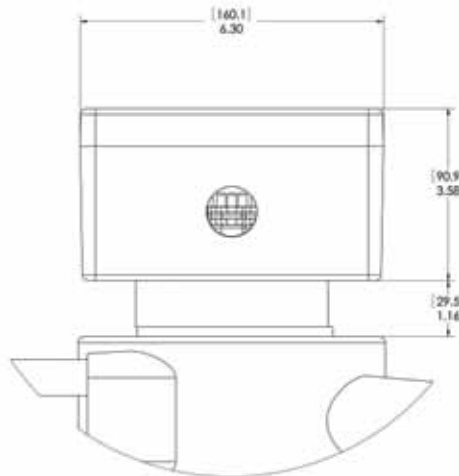

NEMA 4 Enclosure

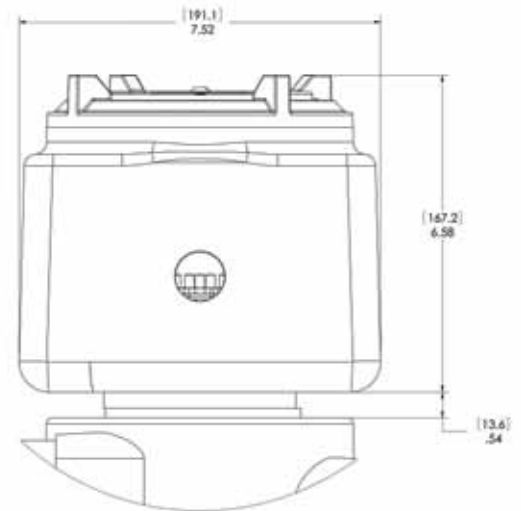

NEMA 7 Enclosure

Compact, Safe Heating for Gases, Solvents, Volatiles & Viscous Fluids



The **DFX 750** is a compact, electric in-line circulation heater designed to quickly and safely heat liquids and gases. This cast-in-aluminum heat exchanger heats fluids indirectly providing a clean heating environment. This design also protects oils and other viscous fluids from thermal breakdown often found in direct immersion applications. The heater elements are protected from corrosive attack and yet provide rapid heat up of process fluids. The excellent thermal conductivity of aluminum provides fast

thermal response and excellent controllability. Optional dual fluid path designs provide heat/cool capabilities for precise solvent, volatiles and viscous liquid temperature control. Or the dual tubing can be used to double the flow rate, halve the pressure drop or be used in a heat/heat configuration.

DESIGN FEATURES

- **Low Mass Design**
 - enables quick thermal response
 - ensures excellent controllability
- **Seamless 316 SS Flow Tubing**
 - provides clean, contamination-free application
 - prevents internal leaks
 - allows up to 3,000 psi rating
- **Cast Aluminum Heat Exchanger Body**
 - enables indirect fluid heating
 - ensures robust, ruggedized performance
 - promotes long heater life
- **Dual Fluid Path Capability**
 - permits precision heat/cool temperature control
 - provides higher flow rate capability
- **UL® Recognition & Certified Ex-Enclosures**
 - safe laboratory and industrial use
 - North American and European HazLoc ratings

APPLICATIONS

- Liquids:**
 - De-ionized water
 - Water, glycol & CIP solutions
 - Lube and heat transfer oils
 - Adhesives, resins & other viscous fluids
 - Temp sensitive inks, coatings & paints
- Solvents:** ACT, EKC, MEK, NMP, Others
- Gases:**
 - Nitrogen & similar gases
 - Supercritical cleaning
 - Steam generation & superheating
 - Sterilization gases
 - Other non-flammable gases

SPECIFICATIONS

Series 750 Construction: 0.75" (19mm) x 0.065" (1.65mm) wall x 227" (575 cm) long, 316 stainless steel fluid tubing embedded in cast, grounded, aluminum heating body

Fluid Connections: Tube ends

Temperature Range: To 200°C (392°F)

Pressure Rating: To 3000 psi (205Bar)

Voltage: To 480V~ (ac), single or three phase

Wattage: To 40,000 Watts

Mounting: Two brackets, with mounting holes

Electrical Enclosure: NEMA 1 standard

OPTIONS

- Heat/Cool configuration
- Process and high limit temperature sensors
- Thermostats for direct or pilot duty control
- Replaceable high limit thermal cutoff device
- NEMA 4, 7, NEC Class 1, Division 2, or ATEX rated electrical enclosure
- Passivated and electropolished wetted surface
- Insulated body up to 200°C (392°F) operation
- Stand-off electrical enclosure